



RW1000 Home Use Warranty

The LifeSpan RW1000 comes with the following warranty for residential use only:

Parts: 1 Year
Frame: 5 Years
Labor: 1 Year

PCE Health and Fitness Warrants that the equipment it manufacturers is free from defects in material and workmanship under normal use and service.

If within the time frame specified above, any part of the RW1000 fails to operate properly, contact your authorized PCE Health and Fitness Retailer to report the problem or contact PCE Health and Fitness at www.LifeSpanfitness.com or (801) 973-9993.

PCE Health and Fitness reserves the right to make changes and improvements to our products without incurring any obligations to similarly alter any product purchased. In order to insure our product warranty and to ensure the safe and efficient operation of LifeSpan equipment, only authorized parts can be used. The product warranty is void if any parts, other than those provided by PCE Health and Fitness are used.

Exclusions and Limitations

- The Warranty does not apply to any defects caused by negligence, misuse, or improper assembly or maintenance.
- This Warranty does not apply to discoloration of paint or plastics.
- PCE Health and Fitness will not be responsible for incidental or consequential damages.
- This Warranty is non-transferable from the original owner.







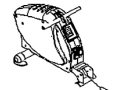
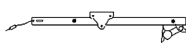
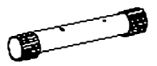

Registration

You must register your LifeSpan product before a warranty claim can be processed and proof of purchase must be demonstrated at the time a claim is made. To complete your registration online, go to www.LifeSpanfitness.com and fill out the online registration or fill out the warranty card provided with your Rower. Registration cards must be completed and sent to PCE Fitness within 30 days of purchase to activate the Product Warranty on your LifeSpan equipment.

Important Safety Instructions

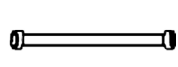
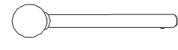
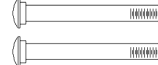
- Always consult a physician before beginning this or any exercise program.
- If you experience chest pains, nausea, dizziness or shortness of breath, stop exercising immediately and consult your physician before continuing.
- Do not wear clothing that may catch under the roller wheels.
- Keep hands and fingers away from the seat roller wheels during use.
- Children: When in use, children should be at least 5 feet away.
- When folded, do not lean on or hang items on the Rower that may cause it to tip or fall over.

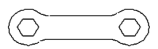
CONTENTS:

- Main Frame 
- Sliding Rail 
- Middle Base 
- Pedals 
- Seat 
- Display 
- Pedal Axle 
- Hardware
 - a. Locking Pin 
 - b. Carriage Bolts 
 - c. Washers 
 - d. Dome Nuts 
 - e. Wrench 
 - f. Allen Wrench 

STEP 1: ATTACH SEAT TO SLIDING RAIL

- a. Remove the 4 Allen Head Screws from the back of the seat.
- b. Place the seat over the seat bracket and tighten all four screws.

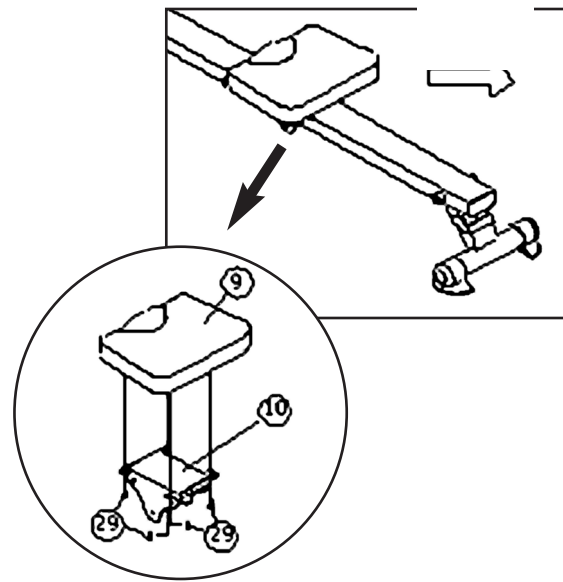

STEP 2: ATTACH MIDDLE BASE TO MAIN FRAME

- a. Align the middle base under the main frame bracket.
- b. Insert the 2 carriage bolts from the bottom.
- c. Place a washer over the end of the carriage bolt and then tighten the dome nut securely.

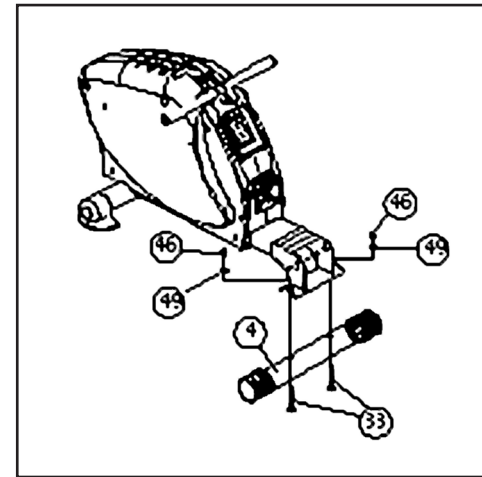

STEP 3: ATTACH SEAT RAIL TO MAIN FRAME

- a. Line the seat rail directly behind the main frame and attach the wire connectors coming from the seat rail and main frame.
- b. Slide the seat rail into the main frame until the holes in the frame align with the holes in the seat rail and insert the locking pin.

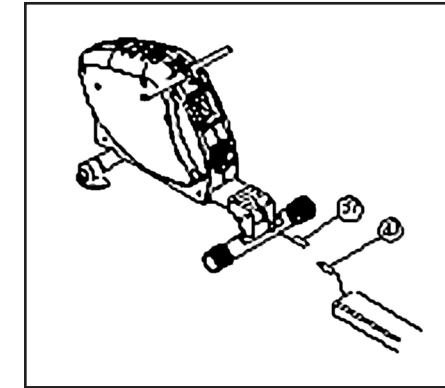

STEP 4: PEDAL ASSEMBLY

- a. Remove the Allen screw, and washer from one end of the pedal axle.
- b. Push the end of the axle through the hole in the frame and rail, with a pedal and spacer on one side. Add the spacer and then the pedal to the opposite side.
- c. Using an Allen Wrench on each end of the axle, tighten the Allen Screw with washer that was removed earlier.

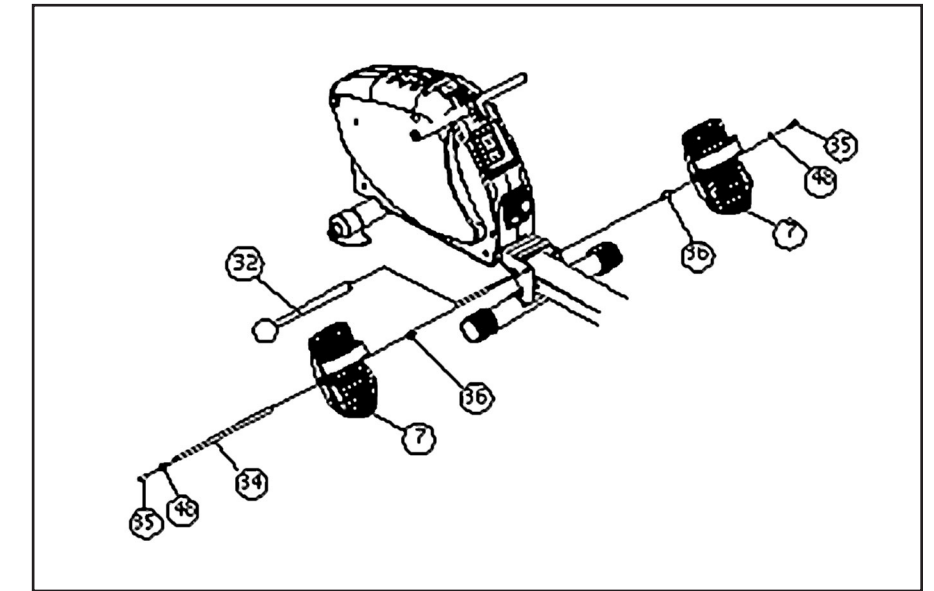

STEP 5: INSERT DISPLAY CONSOLE

- a. Push the supplied AA battery into the back of the display.
- b. Connect the cable inside the hole in the front of the main frame with the connector on the back of the console.
- c. Push the display console into the hole in the main frame until secure.

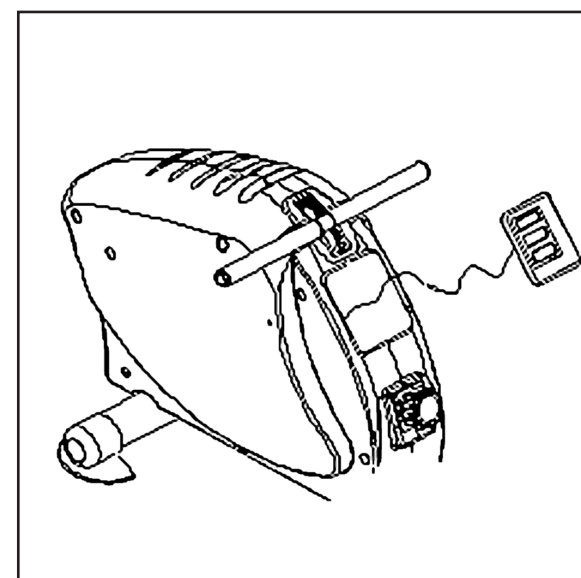
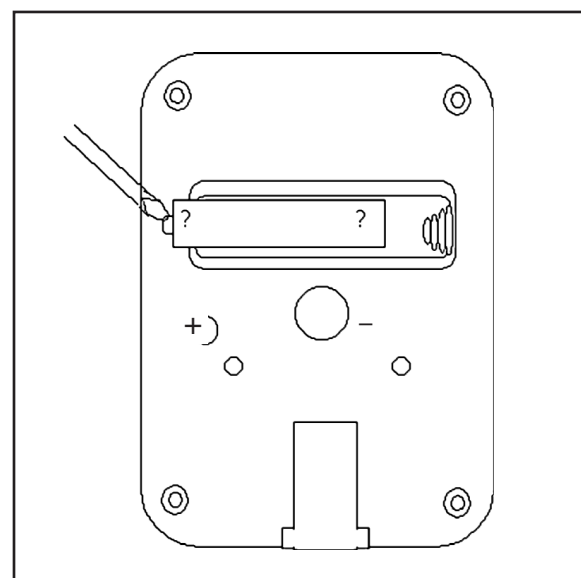

Note:

- If the display is illegible or only partially appears, remove the battery for 15 seconds and replace.
- The battery will need to be replaced approximately once per year.

FOLDING/UNFOLDING

- a. To fold the RW1000 Rower, first pull up on the front of the seat rail to remove pressure from the locking pin.
- b. Remove the locking pin.
- c. Fold the Seat Rail until the holes in the seat rail are aligned with the second set of holes in the main frame and re-insert the locking pin.

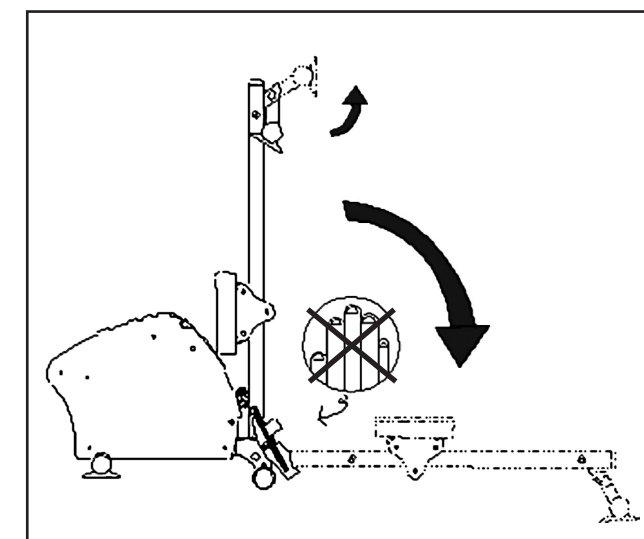
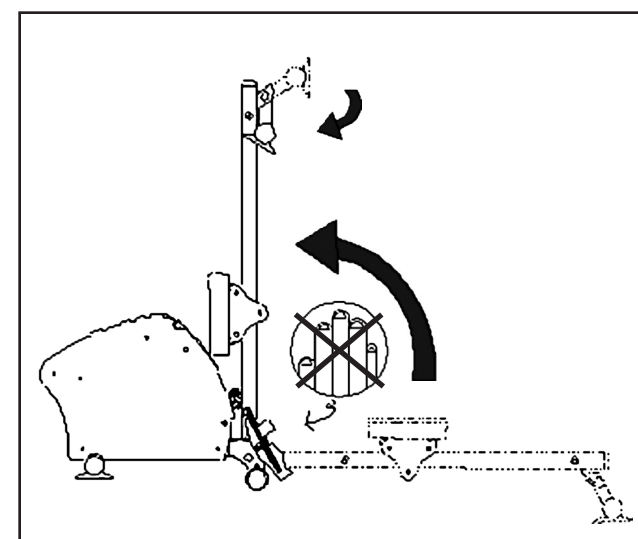

OPERATION

Resistance – To increase the tension turn the adjustment knob to a higher number and to reduce the tension, turn the knob to a lower number.

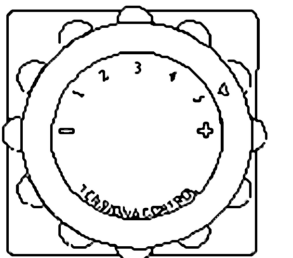

Console Readouts

The console will automatically turn on when the Rower is in use. If there is no movement for over 4 minutes the console will automatically turn off.

PAGE: Press the "PAGE" button to scroll between functions on the console.

RESET: Press the "RESET" button for 3 seconds to reset all values to zero.

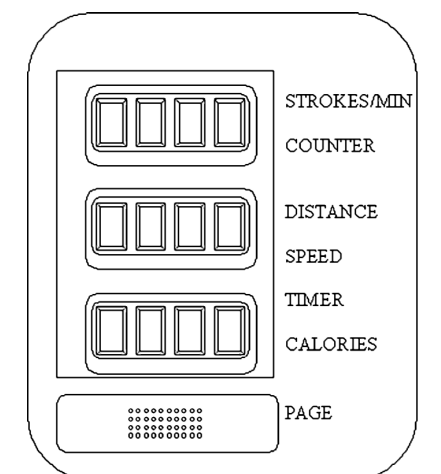

Note:

- If the display is illegible or only partially appears, remove the battery for 15 seconds and replace.
- The battery will need to be replaced approximately once per year.